

***ROCKVILLE  
PARTITIONS  
INCORPORATED***  
***Installation Instructions for  
FM, OH, and CH Series  
Powder Coated or Stainless Steel  
Toilet Partitions.***

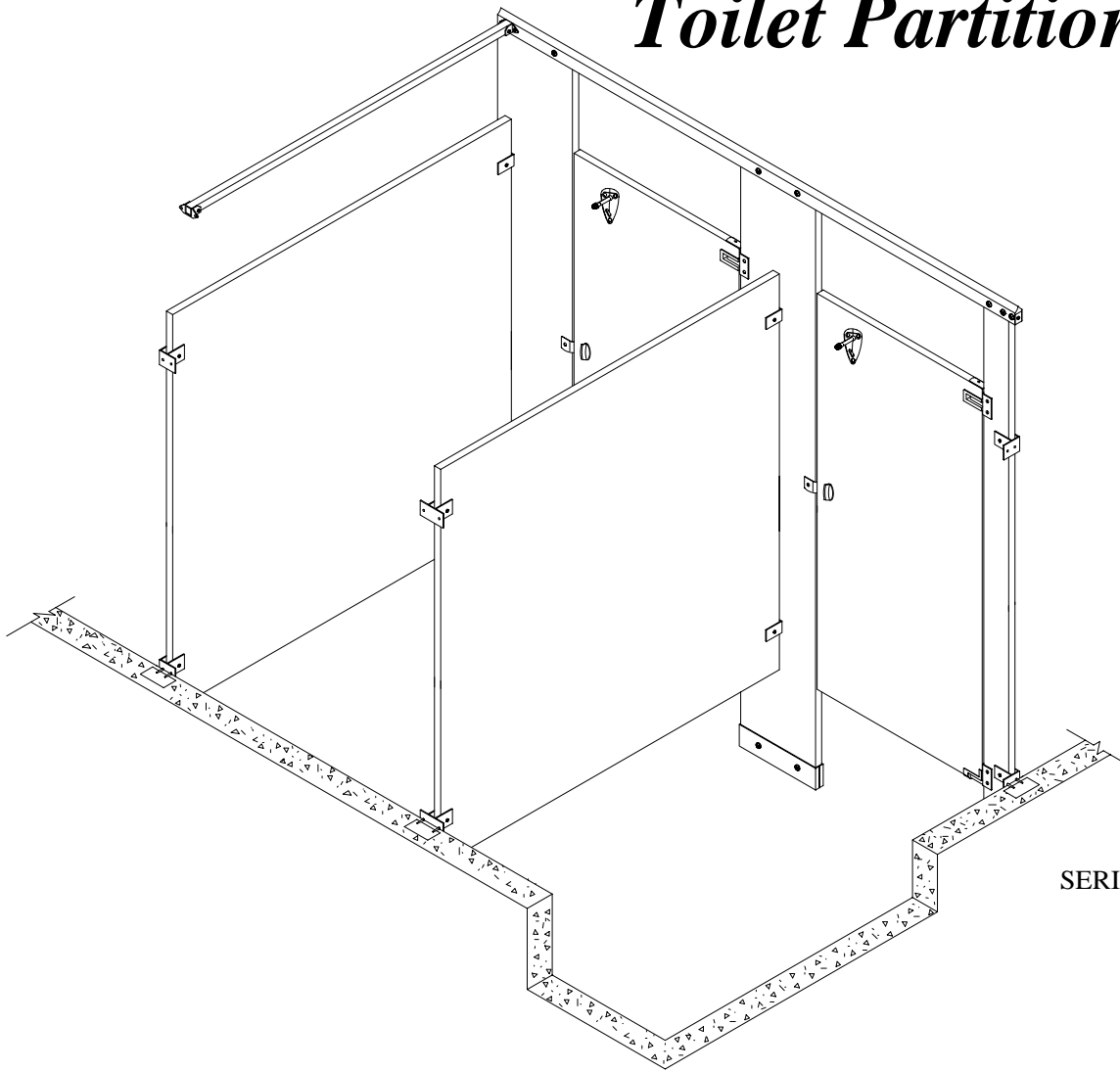

SERIES OH-5

**IMPORTANT!**

- \* PLEASE READ ALL INSTRUCTIONS AND STUDY DRAWINGS BEFORE BEGINNING
- \* VERIFY ALL DIMENSION ON JOB PRINTS WITH ACTUAL JOB CONDITIONS
- \* IN SERIES "OH" BE SURE ALL PILASTERS ARE RIGHT SIDE UP
- \* FIRST HINGE HOLE SHOULD BE 12 3/16" FROM BOTTOM OF PILASTER
- \* THRU BOLTS ARE USED ON DOOR HARDWARE AND WHS SCREENS ONLY !!

# **STEP ONE:**

## **LAYOUT AND MOUNTING BRACKETS**

- A. Establish and mark center line of pilasters, measuring out from back wall at each end of stall run.  
(Refer to ceiling bolt layout on Series CH)
- B. Establish and mark center lines of top and bottom wall brackets (if possible locate in mortar joints.)  
NOTE: Series FM and CH require a third wall bracket in the center to mount the pilaster to the wall.
- C. Measure from side wall and center of pilasters for floor fasteners according to job print, mark. Refer to chart on right for center to center distance of floor fasteners.
- D. Mark all bracket holes using the brackets as a template.
- E. Drill 1/4" holes for all wall brackets.
- F. DRILLING:
  - \* Series OH-5 - Drill 1/4" hole for floor fasteners.
  - \* Series FM-1 - Drill 5/8" hole for floor bolts
  - \* Series CH-1 - Drill 7/16" hole in structural beam before finished ceiling is applied (locate in same manner as floor anchors.)

DIMENSIONS FOR DRILLING FLOOR FASTENERS			
PILASTER SIZE	NO. OF BOLTS	PIL. EDGE TO C <sub>L</sub> OF BOLT	C <sub>L</sub> TO C <sub>L</sub> OF DRILLING
2"	1	1"	—
3"	1	1 1/2"	—
4"	2	1 3/8"	1 1/4"
5"	2	1 3/8"	2 1/4"
6"	2	1 3/8"	3 1/4"
8"	2	1 3/8"	5 1/4"
10"	2	1 3/8"	7 1/4"
12"	2	1 3/8"	9 1/4"
14"	2	1 3/8"	11 1/4"
18"	3	1 3/8"	7 5/8"
24"	3	1 3/8"	10 5/8"

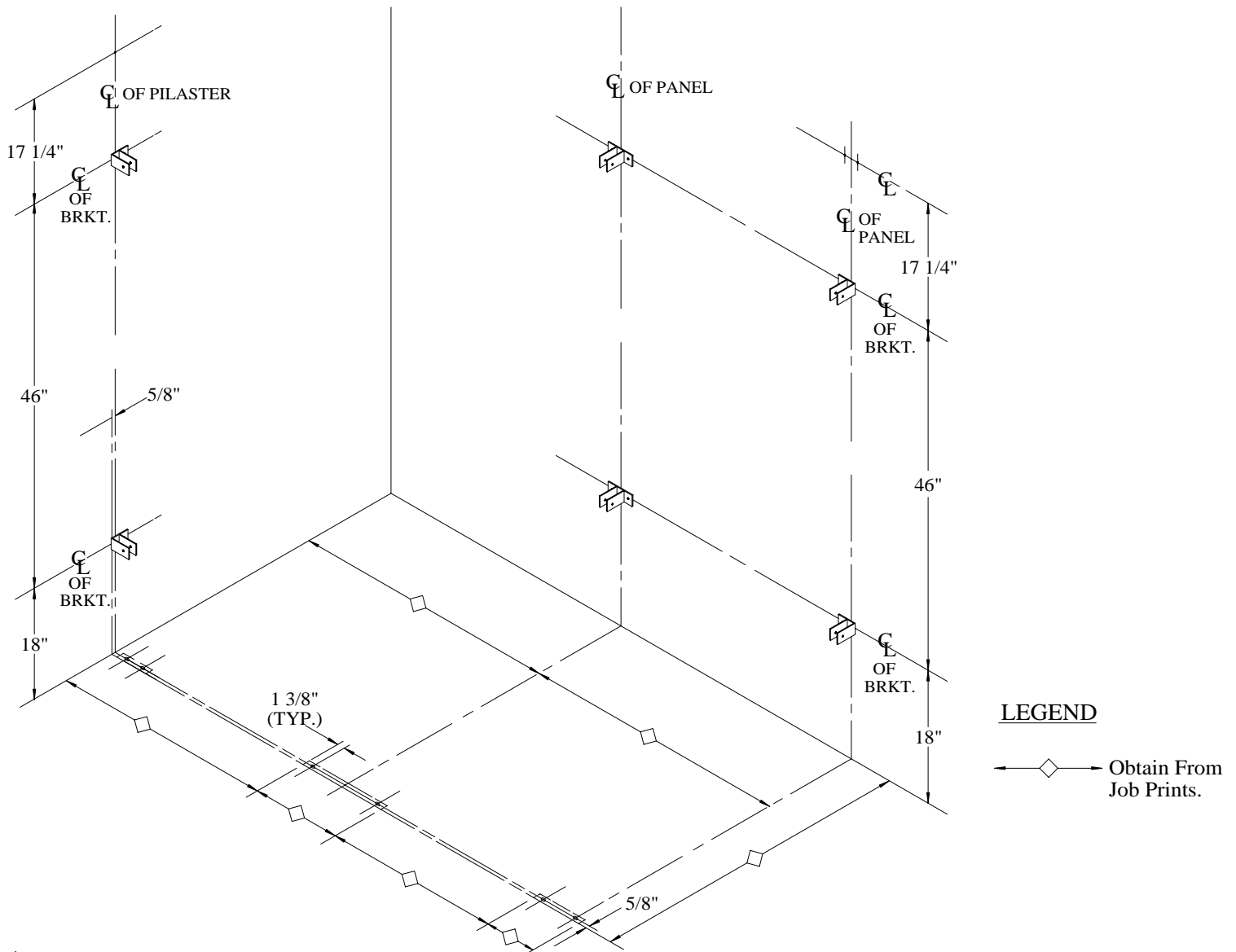

**STEP TWO - A:**  
**POSITIONING PANEL**

- A. Place some type of support (adjustable if possible) in position to hold panel. (See elevation for height off floor)
- B. Set panel on support and into wall brackets.  
DO NOT FASTEN

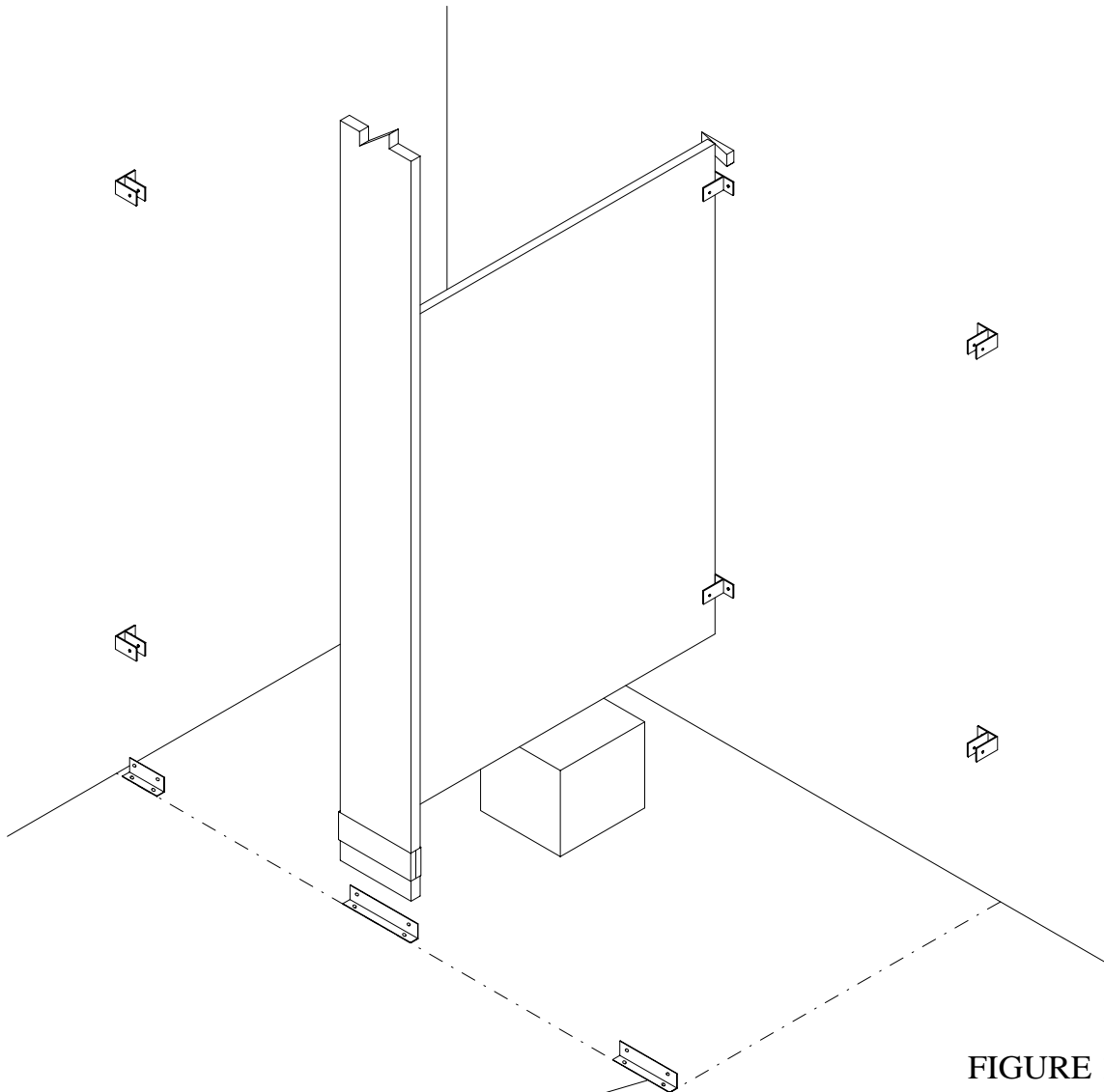

Floor plates for Series "OH" only  
For all other series refer to  
page 3 for pilaster connections

# **STEP TWO - B:** **PREPARING PILASTER ANCHOR**

## Series OH-5

- \* Place plastic anchor in floor holes.
- \* Over each anchor, place the adjustable floor plate, washer, and fasten to floor with #12 x 2" torx screw.

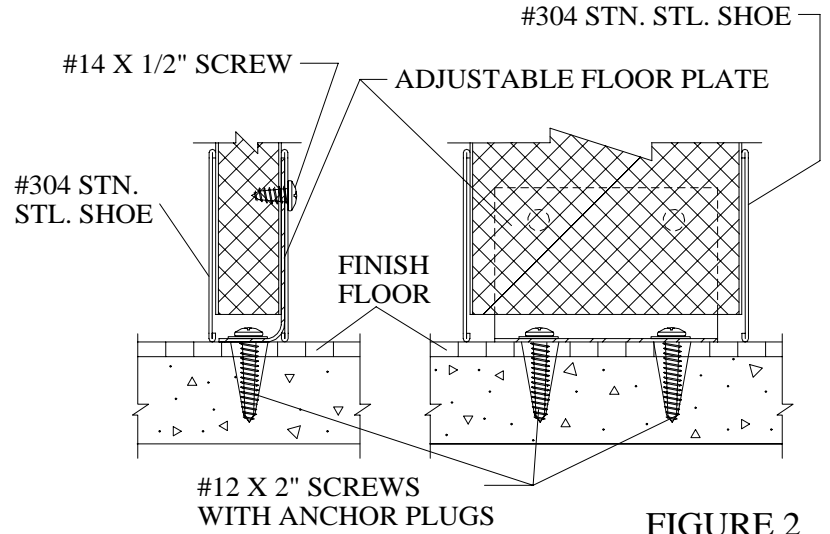

FIGURE 2

## Series FM-1

- \* Place expansion shield in floor holes.
- \* Screw (hand tight) 3/8"-16 x 5" long stud into shield.
- \* On each stud place (1) washer.
- \* Screw (2) 3/8"-16 hex nuts on to each stud, tighten the two hex nuts together with a wrench then tighten stud into expansion shield.
- \* Release bind on nuts and run down on the studs.
- \* Place (1) washer over each stud.

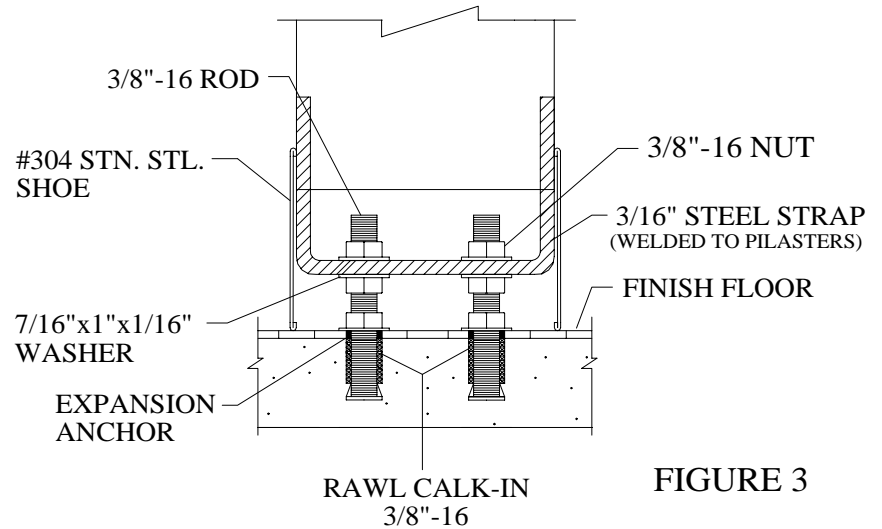

FIGURE 3

## Series CH-1

- \* Insert 5" rods through holes in beam before finished ceiling is applied.
- \* Drop washer over rod.
- \* Screw on (1) 3/8"-16 hex nut.
- \* Install second washer and nut under beam.
- \* Tighten all nuts and apply finished ceiling.

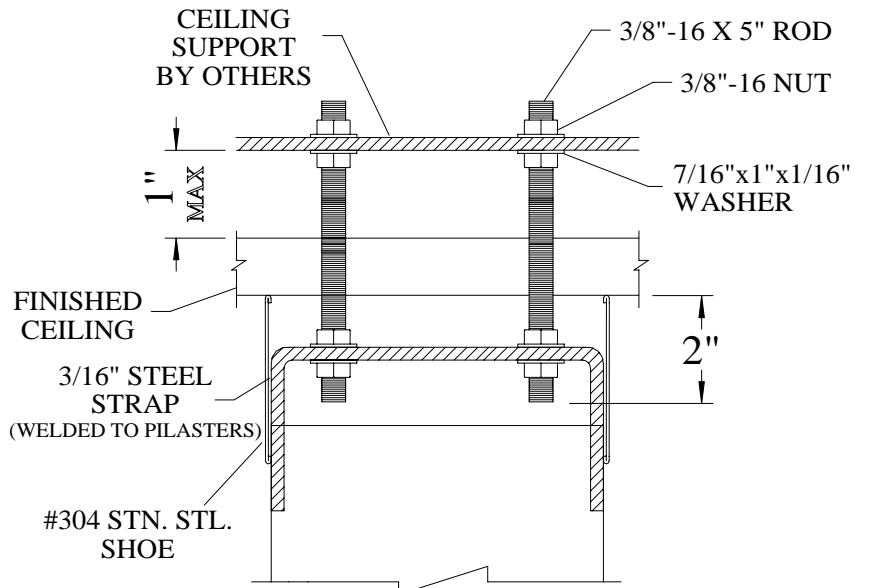

FIGURE 4

# **STEP TWO - C:**

## **ATTACHING PILASTERS**

- C. Fasten panel brackets to pilasters with #14 x 1/2" torx screws at proper locations. (see detail that corresponds with job series)
- D. Slide stainless steel shoe on pilasters. (Do Not Fasten)
- E. POSITIONING PILASTERS:

- \* Series OH-5

- Place pilaster in position over adjustable floor plate.

- \* Series FM-1

- Slip pilaster over floor stud.

- Place (1) washer and nut down over stud loosely.

- \* Series CH-1

- Place (1) nut and washer on stud.

- Slide pilaster on stud.

- Slip on last washer and nut loosely.

F. Fasten pilaster brackets to panel with #14 x 1/2" torx screws.

G. Plumb pilaster, place wedge at top rear of panel between panel and wall. (see figure 1)  
Repeat for each compartment.

H. Series FM and CH ONLY.

Attach panels to wall brackets at this time, drilling 3/16" holes and fastening with #14 x 1/2" torx screws

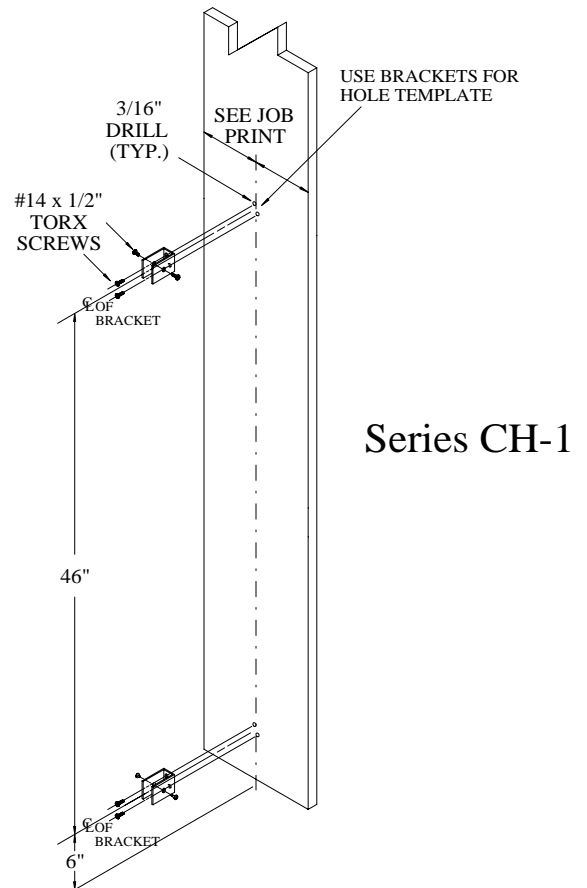
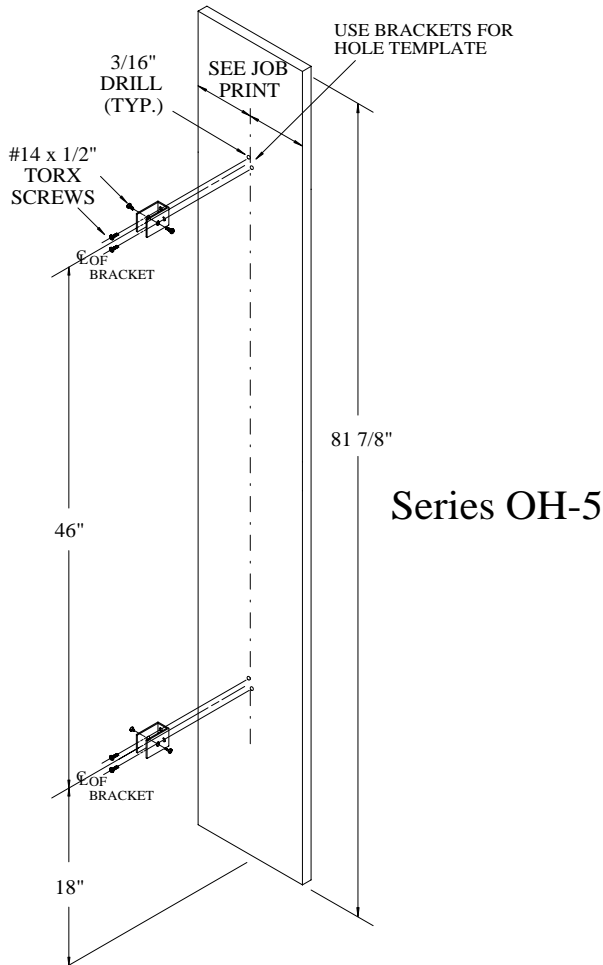
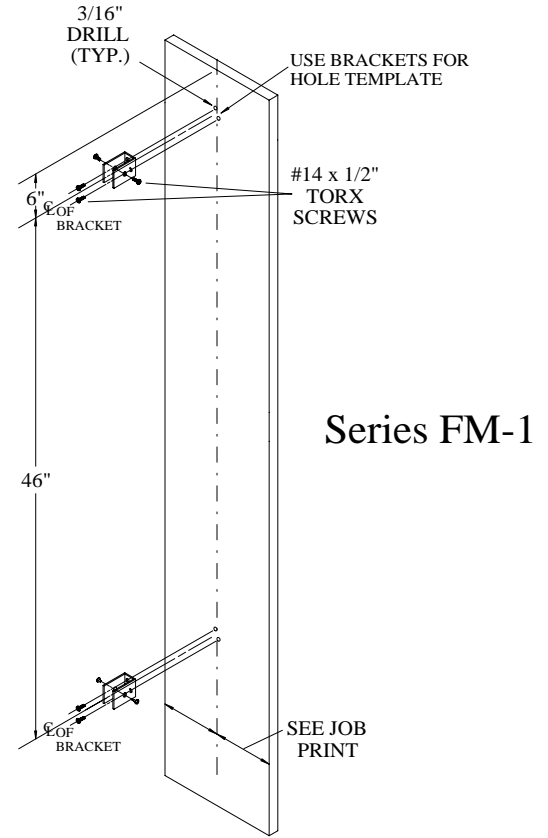

# **STEP THREE:**

## **MOUNTING HEADRAIL SERIES "OH" ONLY**

- A. Level headrail on top of pilasters from one compartment to the next.
- B. Establish location of headrail wall brackets on side wall by placing the bracket on one end of the headrail and lowering it into position. mark position and remove headrail. (see detail "A")
- C. Drill 1/4" hole into wall and insert anchors.
- D. Fasten to wall with #12 x 2" torx screws.
- E. Replace headrail and drill 3/16" hole from the inside of the compartment, securing to bracket with #14 x 1/2" torx screw.
- F. Drill 3/16" holes and secure panels to wall brackets with #14 x 1/2" torx screws
- G. Drill 3/16" hole and attach headrail chair bracket to end pilaster with #14 x 1/2" torx screws. (see detail "C")
- H. Place headrail wall bracket on one end of headrail, place in position and mark.
- I. Drill 1/4" holes and fasten chair bracket to back wall with #12 x 2" torx screws. (see detail "B")
- J. Cut headrail to length and slip into brackets.
- K. Drill 3/16" holes and attach brackets to headrail at each end with #14 x 1/2" torx screw.

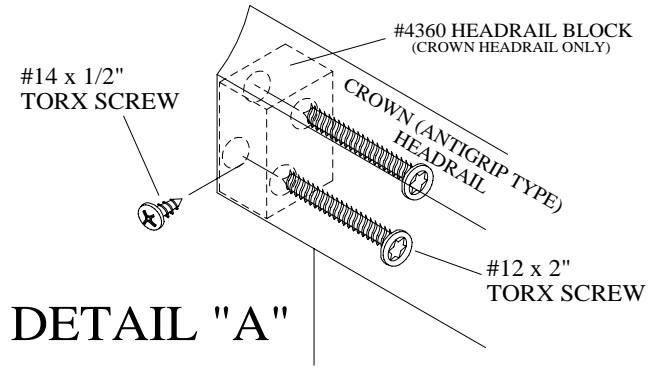

**DETAIL "A"**

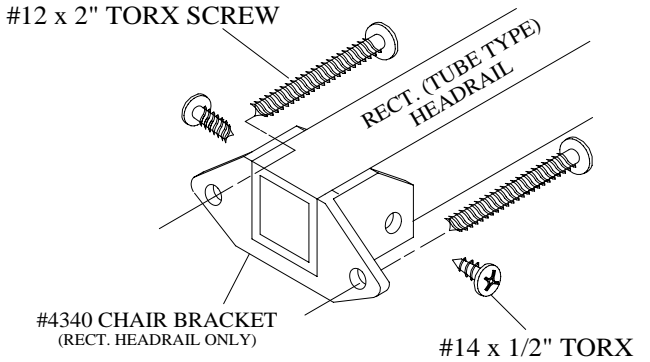

**DETAIL "B"**

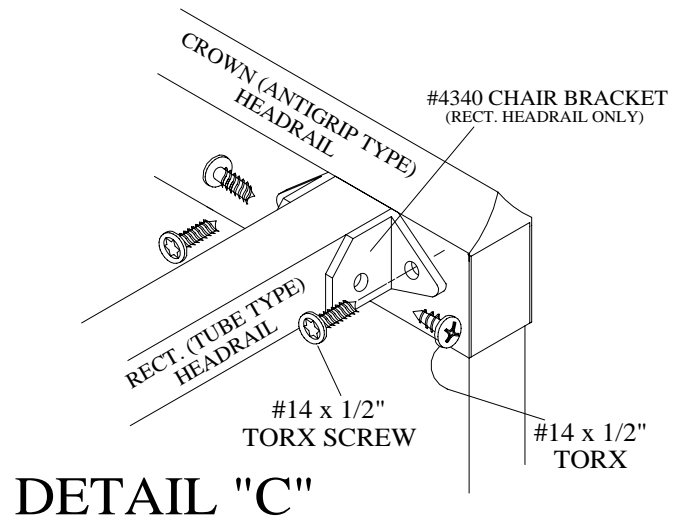
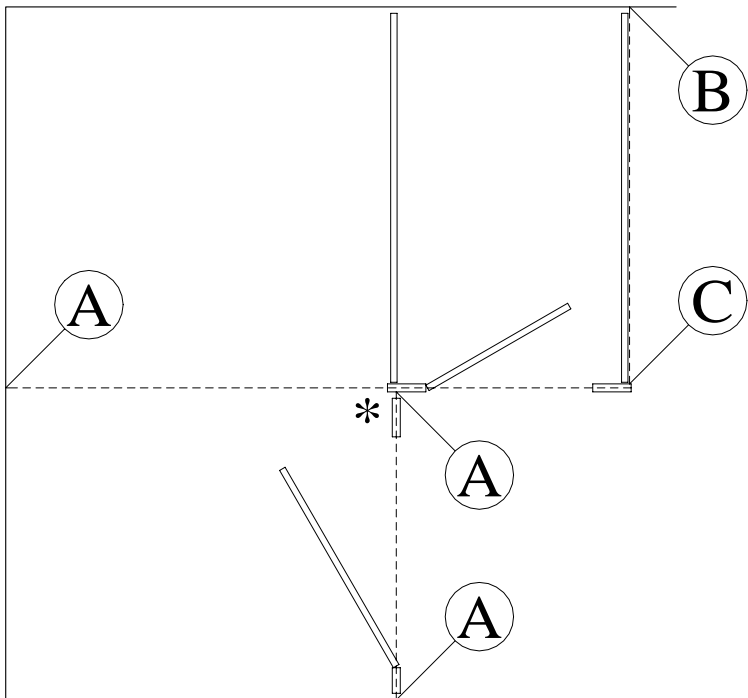

**DETAIL "C"**

\* = SAME CONNECTION AS DETAIL "A"  
BUT USE #14 x 1" SCREWS INTO  
PILASTER

## STEP FOUR:

### SET DOOR OPENINGS

- A. Position wall pilaster - plumb and secure.
- B. Using wall pilaster as a reference point, position each pilaster to required door opening (see shop drawings) and secure.

#### C. FASTENING PILASTERS:

##### \* Series OH-5

Fasten pilaster to floor plate with #14 x 1/2" torx screw through holes prepunched in shoe. Locate screw on back side of pilasters. (see figure 2)

##### \* Series FM-1

Adjust hex nuts to level pilasters and tighten all nuts firmly.

Secure stainless steel shoe with #14 x 1/2" torx screw. (see figure 3)

##### \* Series CH-1

Adjust hex nuts to level pilasters and tighten all nuts firmly.

Secure stainless steel shoe with #14 x 1/2" torx screw. (see figure 4)

- D. Drill 3/16" holes and fasten headrail to the pilasters from inside the compartment with #14 x 1/2" torx screw. This is to be done one compartment at a time.

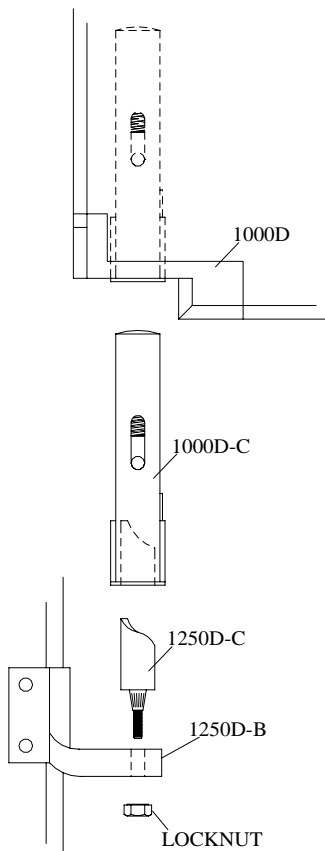

**BOTTOM  
HINGE  
ASSEMBLY**

\* Use lever latch (2000F) on handicap doors

\*\* Use coat hook without bumper on handicap doors

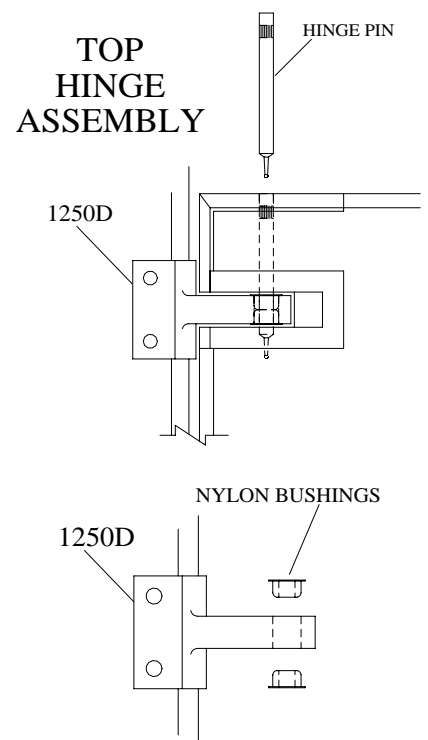
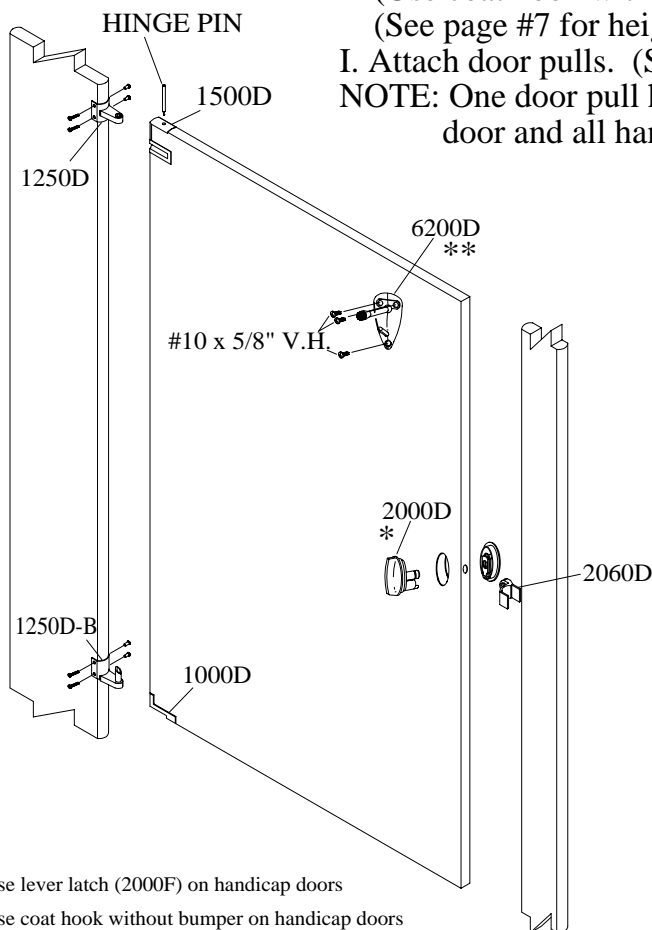

## STEP FIVE:

### HANGING DOORS

- A. Mount hinge brackets on pilasters with sex bolts in predrilled locations.  
NOTE: If pilasters are not predrilled see page 11 for template location
  - B. Insert spring loaded #1000D-C into bottom hinge casting on door. Set door into place positioning the #1000D-C over the male cam #1250D-C.
  - C. Thread a sex bolt from the door kit into the top of the hinge pin and insert pin through top of door and hinge bracket #1250D, DO NOT SEAT PIN ALL THE WAY AT THIS TIME. If door does not close to desired position then, pull top hinge pin out and remove door. Loosen locknut on male cam and rotate cam to desired position, re-tighten lock nut, replace door and hinge pin.
  - D. Push all top hinge pins in all the way until pin snaps into place. Remove sex bolt from hinge pin.
  - E. From inside of compartment insert male butterfly knob through concealed latch assembly. (Use lever latch on Handicap doors)
  - F. Align outside female slotted cover with pins of male knob, press firmly until locked into place.
  - G. Align stop and keeper with latch bolt, drill 1/4" hole and fasten with 1 1/4" pilasters sex bolt.
  - H. Attach coat hooks with #10 x 5/8" vandal head screws. (Use coat hook without bumper on Handicap stalls only) (See page #7 for heights and location)
  - I. Attach door pulls. (See page #7 for heights and location)
- NOTE: One door pull has been furnished to each outswing door and all handicap doors.

# DOOR PULL & COAT HOOK INSTALLATION

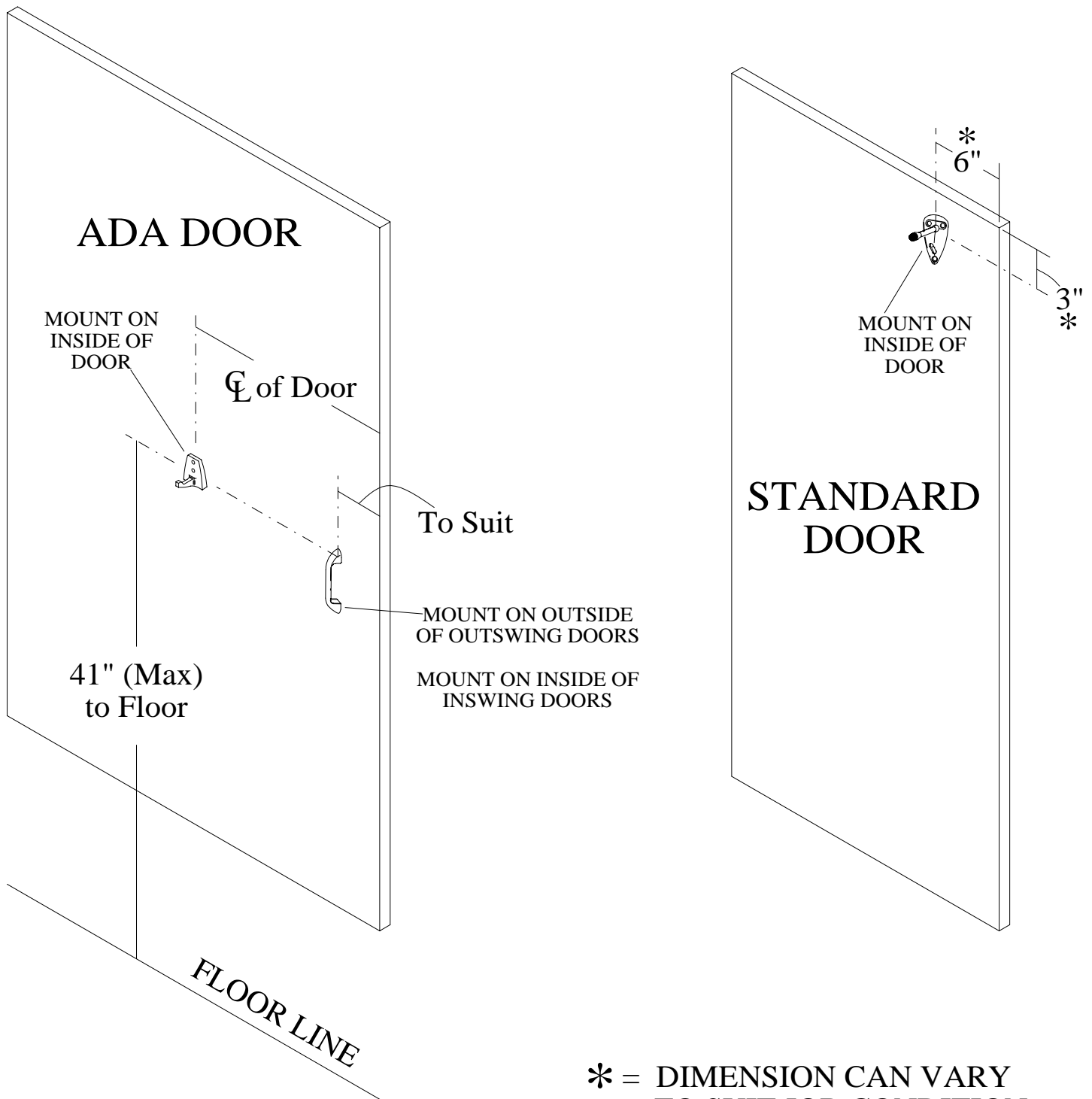

\* = DIMENSION CAN VARY TO SUIT JOB CONDITION

# ALCOVE INSTALLATION

## SERIES OH-5

- A. Establish center line from back wall and mark location on the floor of the 3" integrated pilaster, drilling a 1/4" hole, 1 1/2" from the end of the pilaster.
- B. Establish and mark the center line of all top and bottom wall brackets (if possible locate in mortar joints).
- C. Using brackets as a template mark and drill 1/4" holes for wall brackets.
- D. Insert plastic anchors into all holes, and secure wall brackets With #12 x 2" torx screw.
- E. Secure floor plate to floor with #12 x 2" torx screw, 1/4" washer and anchor plugs.
- F. Place a support under the panel while setting it into the wall brackets. (Do Not Fasten)
- G. Slide the stainless steel shoe on the pilaster and place it on the floor plate while at the same time sliding the open end of the pilaster over the panel.
- H. Level and secure panel to wall brackets with #14 x 1/2" torx screws.
- I. Plumb 3" integrated pilaster and attach with (3) #14 x 1/2" torx screws on each side of the pilaster.
- J. Position wall pilaster, plumb and secure being sure to keep required door opening. (See shop drawings)
- K. See step #5 to hang doors.

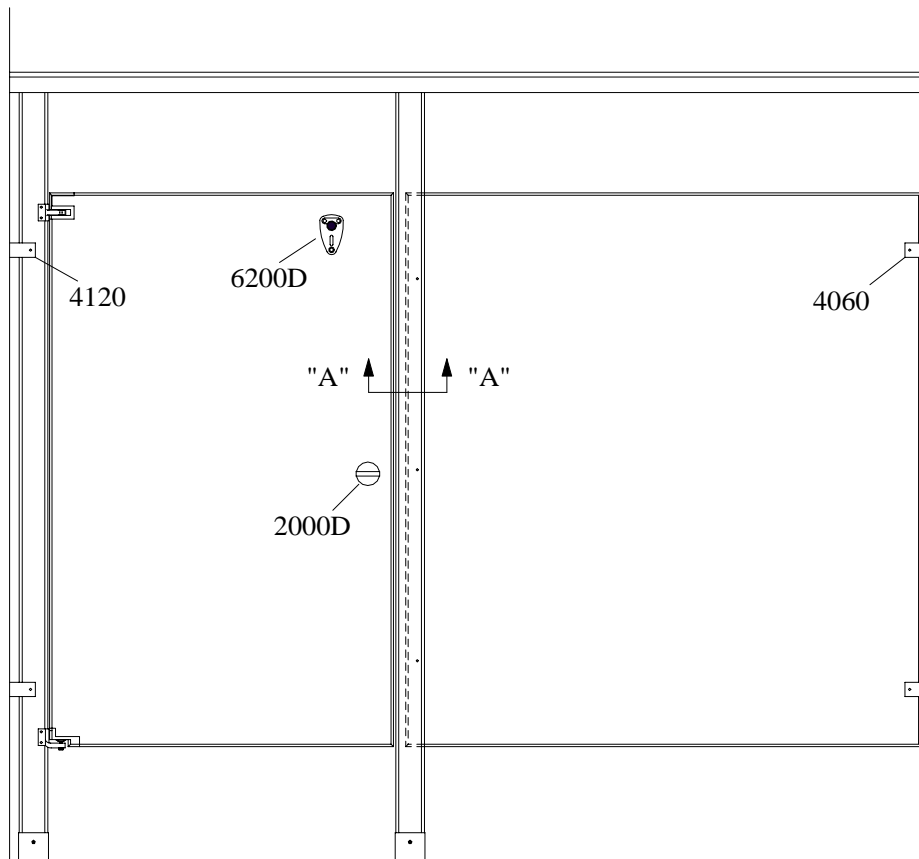

### Section A - A

NOTE: Minimum Integration - 1"  
Maximum Integration - 2 1/2"

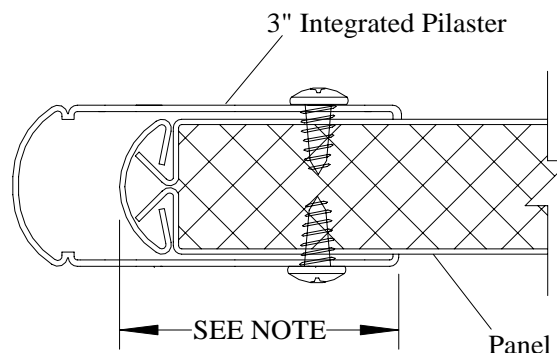

# **ALCOVE INSTALLATION**

## **SERIES FM and CH**

In Series FM and CH alcoves the center pilaster is installed perpendicular to the panel to gain maximum strength. The installation is basically the same procedure as installing a standard series FM or CH toilet compartment. Please refer to the beginning of the text for step by step instructions. This type of alcove utilizes a flat strike and keeper due to its configuration.

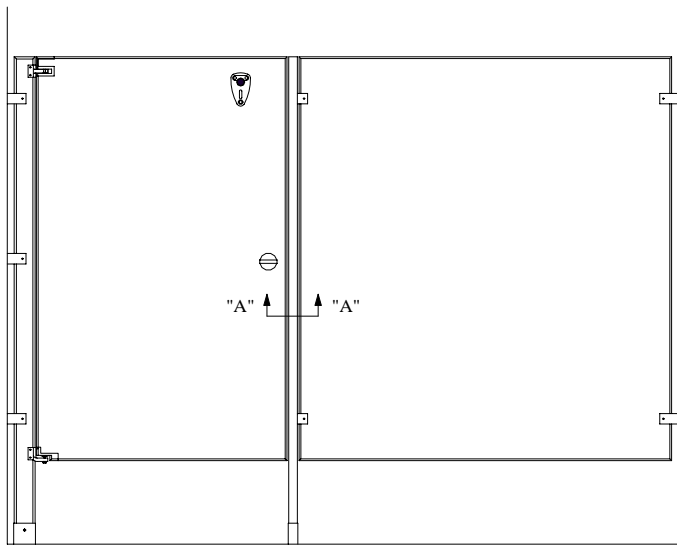

**Series FM**

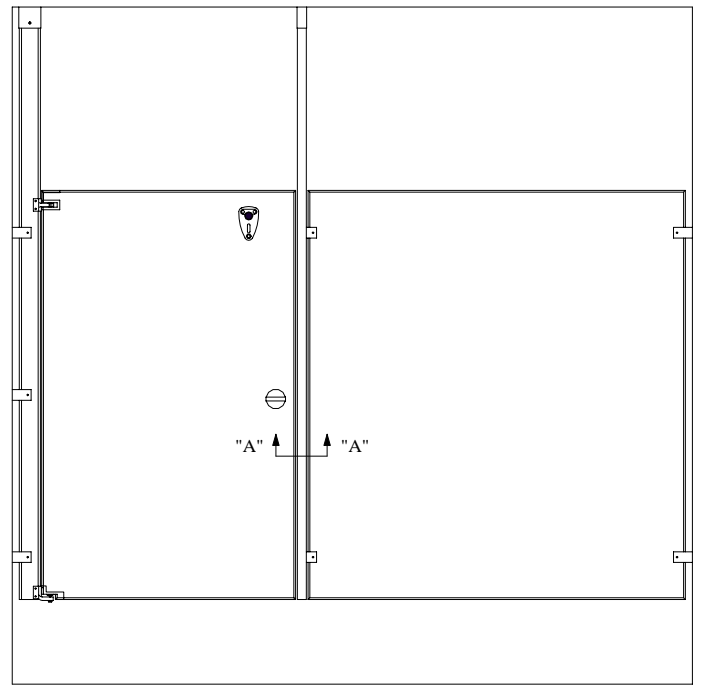

**Series CH**

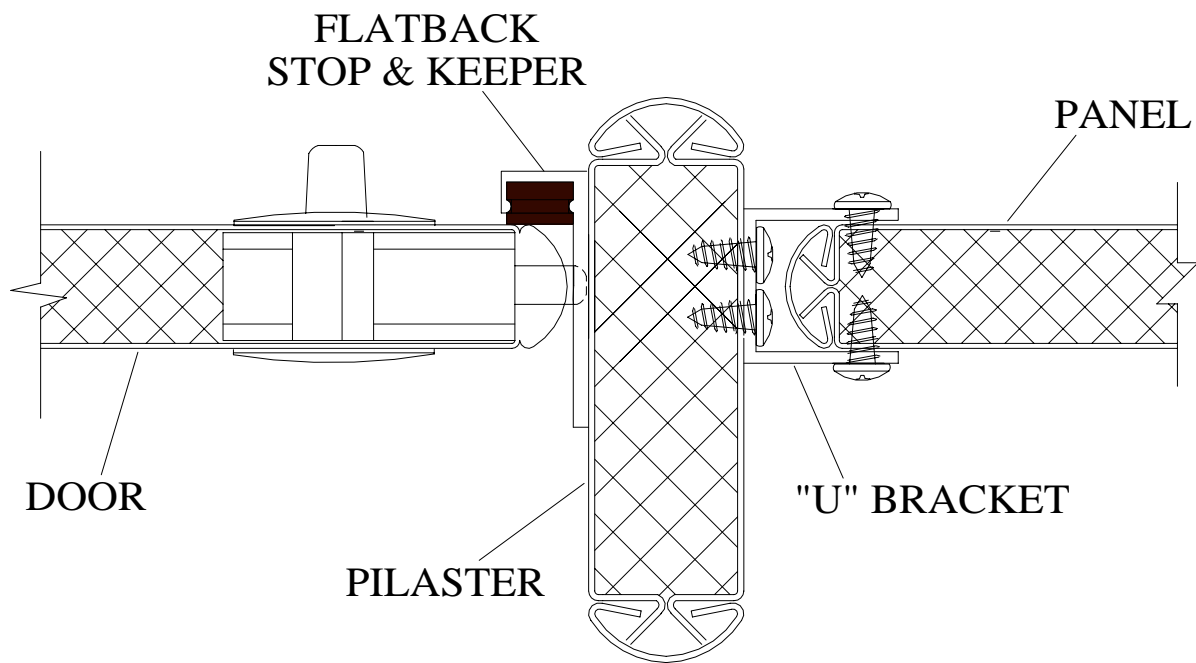

**SECTION A - A**

# URINAL SCREEN

General Partitions manufactures several different styles of urinal screens for all types of applications. The most common model is the WHS-1 or the wall hung screen.

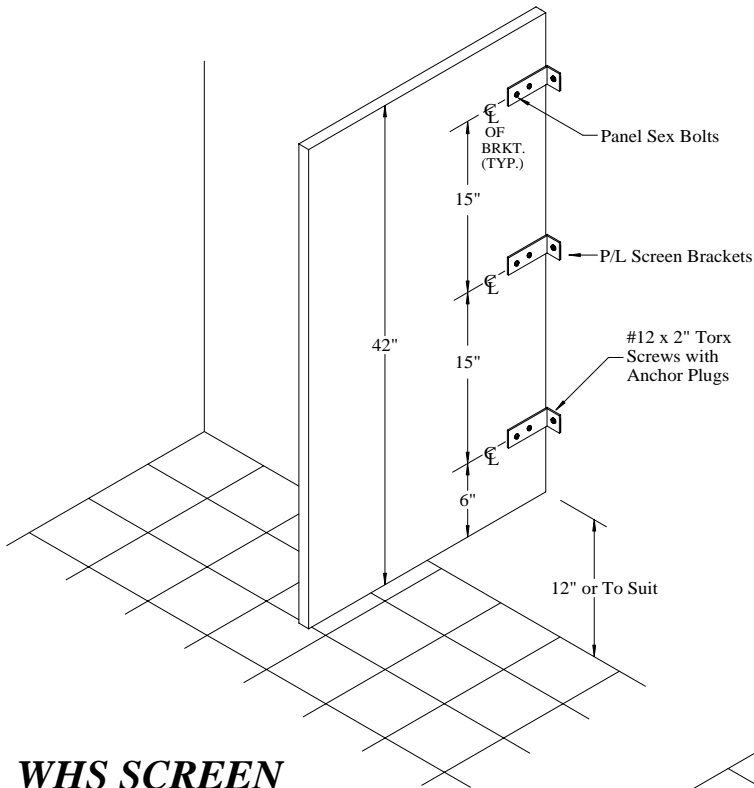

**WHS SCREEN**

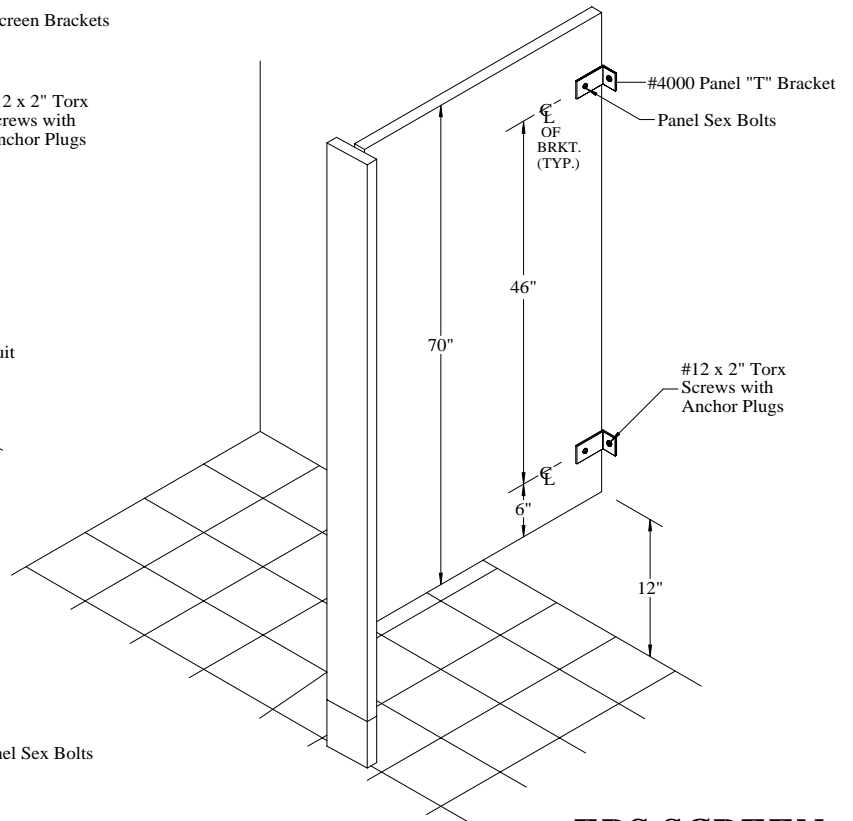

**FBS SCREEN**

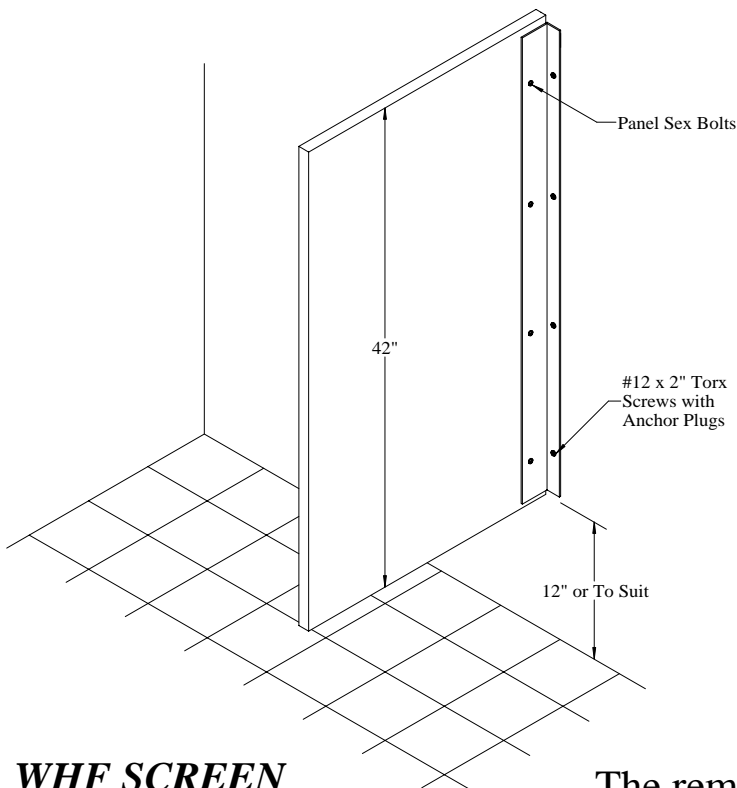

**WHF SCREEN**

The remainder of the screens are basically installed in a similar manner to the toilet partitions

# #9000 GRAB BAR REINFORCING KIT

\* One kit required per grab bar (2 Flanges)\*

Contains 6 each: Sex bolts, nuts, sleeves and washers per grab bar.

- A. Position grab bar on the panel at the specified location, and mark w/ center punch all holes.
- B. Drill 1/4" hole through panel, remove burrs.
- C. Open all OUTSIDE holes to 3/8" diameter opposite grab bar side only.  
DO NOT DRILL THROUGH PANEL.
- D. Insert sleeves, bolt and washer from 3/8" side.
- E. Bolt grab bar to panel using sex nut on inside, tighten all bolts securely.

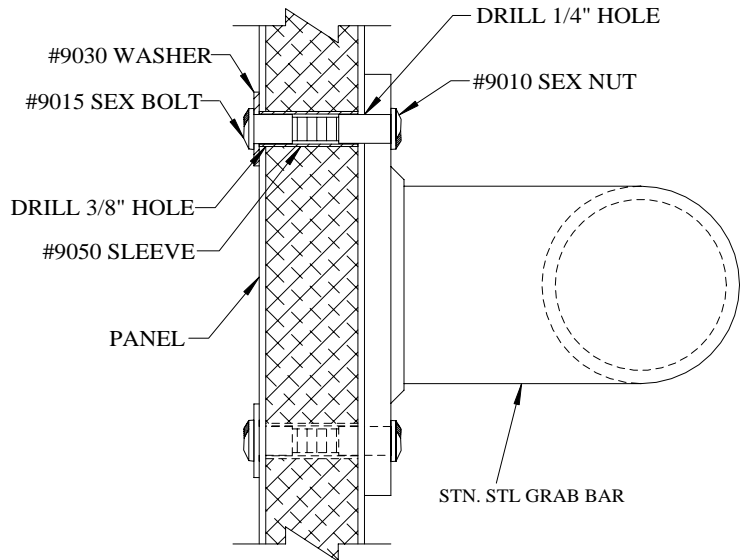

# PILASTER DRILLING LOCATIONS FOR DOOR HINGES

In most cases the pilasters will already be predrilled. There will be instances when the pilasters will be supplied un drilled, such as in the event the job was supplied on a ultra 2 day shipment program.

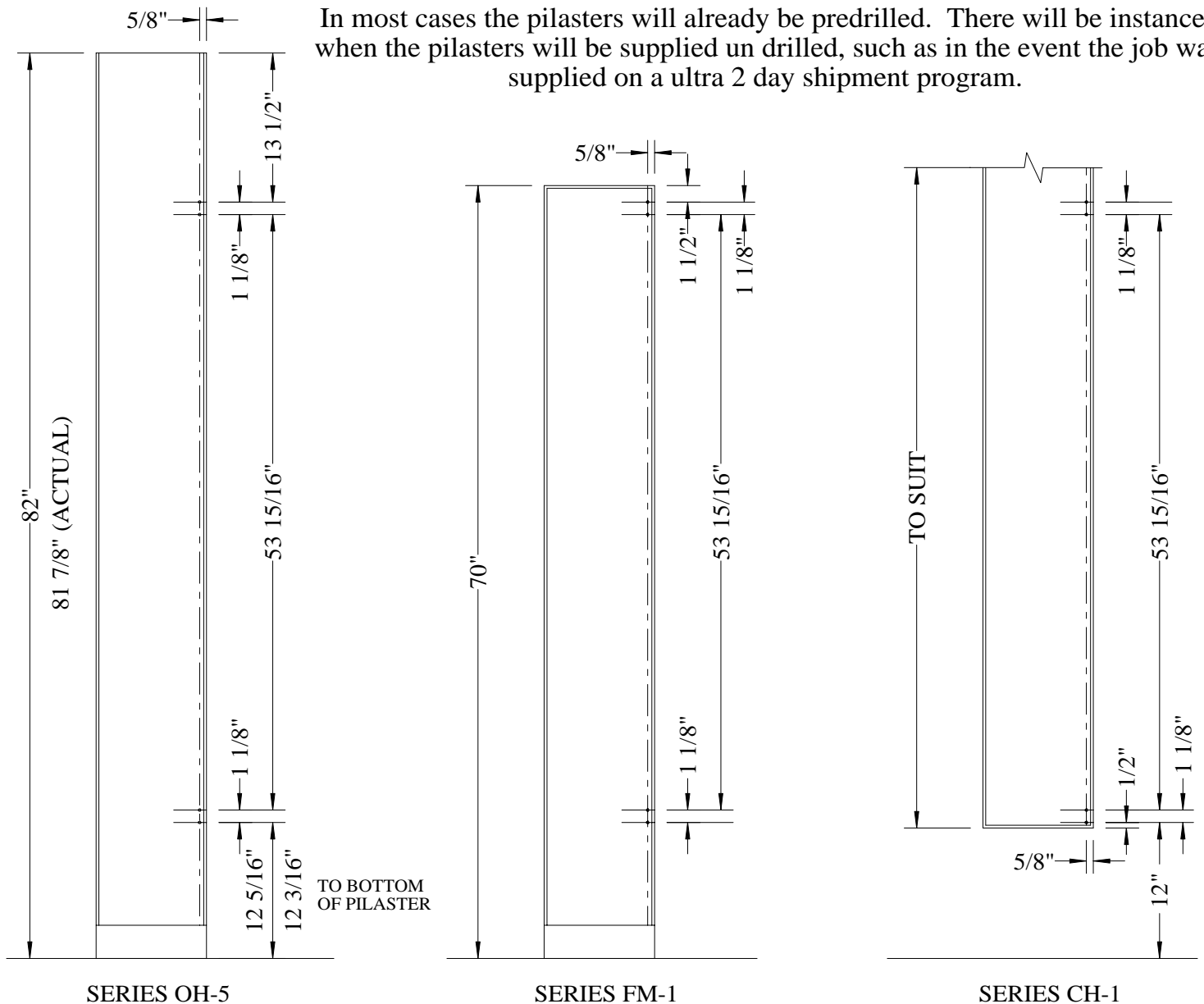

SERIES OH-5

SERIES FM-1

SERIES CH-1